

## TSF SitRep n°2 – 23/03/2015

*All of Télécoms Sans Frontières' (TSF) operations are carried out in agreement with the Office of the Government of the Chief Information Officer (OGCIO) of the Prime Minister*

*TSF's mission in Vanuatu is supported under mandate of the European Commission Humanitarian Aid & Civil Protection (ECHO)*

### General Context

The severe tropical cyclone Pam entered in Vanuatu Territorial Waters on 12th March 2015. 250km/h winds destroyed vast parts of the country, including a high impact on telecommunications infrastructures. These infrastructures are being re-established little-by-little on a daily basis. Assessments are still underway, however some key figures<sup>1</sup> can be found below:

#### TOTAL AFFECTED

166,000

on 22 islands

#### CONFIRMED FATALITIES

11

as stated by the Prime  
Minister of Vanuatu

#### IN NEED OF SHELTER

65,000

### TSF Deployment

**Emergency response team I:** A team of 5 ICT specialists deployed to preposition in Brisbane on Sunday March 15th 2015. The TSF team arrived on Monday 16th in Port-Vila.

**Emergency response team II:** A second team was deployed on 22<sup>nd</sup> March 2015 to reinforce TSF relief efforts in Vanuatu's most affected provinces.

Contacts for all deployed members can be found in the table below.

<sup>1</sup> Vanuatu: Tropical Cyclone Pam [Situation Report No. 8](#) (as of 22 March 2015) - UNOCHA

## Contact list

Name	Position	Location	Phone Contact	E-mail contact
<b>Sébastien LATOUILLE</b>	Head Of Mission	Port-Vila	+678 547 5087 +870 77 63 80 958 +66 845 392 103	vanuatu@tsfi.org
<b>Sébastien LANNES</b>	ICT Specialist	Port-Vila	+678 547 5090 +678 775 2980	vanuatu@tsfi.org
<b>Florian VICHOT</b>	ICT Specialist	Erromango, Taféa	+678 547 50 88 +678 775 2979	vanuatu@tsfi.org
<b>Loïc FINAS</b>	ICT Specialist	Port-Vila	+678 547 5089 +678 775 2987	vanuatu@tsfi.org
<b>Alexander James THOMAS</b>	Communications	Port-Vila	+678 547 7615	vanuatu@tsfi.org
<b>Pascal VILLENEUVE</b>	Logistics	Erromango, Tafea	+678 775 2970	vanuatu@tsfi.org
<b>Monique LANNE-PETIT</b>	Director	Port-Vila	+678 547 5091	vanuatu@tsfi.org

## Coordination

Within the framework of its operational partnership with the United Nations Office for the Coordination of Humanitarian Affairs (UNOCHA) TSF is integrated into Disaster Assessment and Coordination (UNDAC) teams and provides satellite communications means to support field assessments (see *ASSESSMENTS*)

TSF is also coordinating its operations with the Office of the Government of the Chief Information Officer (OGCIO), and has committed to providing data and voice services to 6 Provincial Emergency Operational Centres (PEOC) to communicate with the National Centre (NEOC).

Within the framework of its partnership with the Emergency Telecoms Cluster (UNETC), TSF supports the agency by providing technical assistance as well as participating in ICT Working Groups and coordination meetings.

## Field Assessments

**LUGANVILLE** - GPS : 15°31'60" S et 167°10'1" E

Assessments on the island of Espiritu Santo have shown that Digicell has completely reestablished its network and TVL's network is almost entirely recovered, however surrounding islands in the province of Penama remain out-of-coverage.

### **PENAMA**

A TSF team will be assessing the telecom situation as it stands in the Penama province, focusing on the islands of Pentecost, Aoba and Maewo.

N.B. Logistical constraints mean that assessments will only be able to commence as of Wednesday (25/03).

## Direct assistance to populations

Humanitarian calling operations (HCO) – Free priority IsatPhone calls for affected populations<sup>2</sup>

### **NORTHERN EFATE**

2 days of operations in the north of Efaté. On Saturday 21/03, no/partial coverage in the northern areas of the island.

N° of beneficiary  
families  
20/03/2015  
**59**

N° of beneficiary  
families  
21/03/2015  
**53**

**TANNA – Lenakel: GPS 19°31'48"S 169°15'36"E**

Operations in Lenakel are still in progress

N° of beneficiary  
families  
23/03/2015  
**100**

---

<sup>2</sup> TSF is coordinating with the International Federation of the Red Cross to ensure that its operations do not cross those of the IFRC's *Restoring Family Links*

## Satellite connectivity provisions

### WiFi bridge - NGO central communications centre – Kaiviti

With NGOs and United Nations Agencies centered in Port-Vila, alongside the Emergency Telecoms Cluster of the United Nations, TSF has put in place a WiFi bridge to create a common internet connection for the coordination efforts of relief workers deployed in the area. The connection is available 24/7 and allows responders to communicate with their head and regional offices, send reports and manage day-to-day coordination.

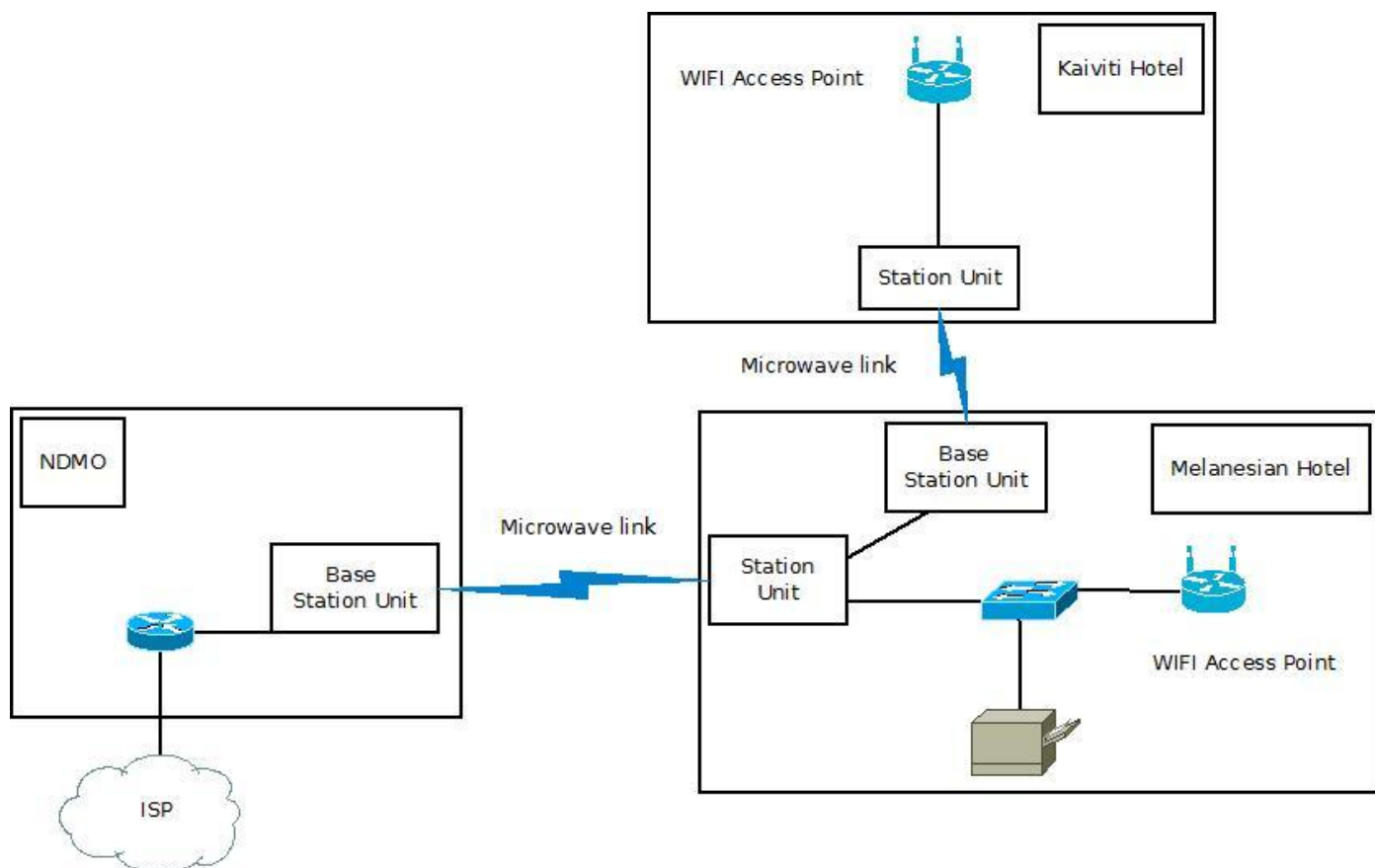

*WiFi bridge architecture – Port-Vila Kaiviti Hotel*

### WiFi bridge - Port-Vila Airport

Support to the United Nations On-Site Operations Coordination Centre (OSOCC) Reception/Departure Centre (RDC) for registration of NGOs arriving in Vanuatu.

### UNETC communications support

The United Nations Emergency Telecoms Cluster (ETC) has requested support from TSF in Tanna. A team has deployed alongside the ETC to provide internet connectivity via BGAN within a coordination hub set up on the island.

### Northern Provincial Hospital – Luganville, Sanma

An IsatPhone has been provided to the Provincial hospital in Luganville for ordering medical supplies from the capital and management of victims transported in planes and helicopters.

## Equipment distribution

Isatphone	Model	SIM	Phone number	Attribution
Isatphone78	Isatphone Pro 2	ISP04	+870776380525	Luganville – Hospital
Isatphone64	Isatphone Pro 2	ISP14	+870776442327	Malekula - Lakatoro
Isatphone76	Isatphone Pro 2	ISP17	+870776442484	HCO Santos
Isatphone60	Isatphone Pro 1	ISP19	+870776442486	Tanna – Isangel
Isatphone72	Isatphone Pro 2	ISP32	+870776466478	HCO Tanna
Isatphone73	Isatphone Pro 2	ISP37	+870776467132	NDMO Port Vila
Isatphone65	Isatphone Pro 2	ISP58	+870776382895	HCO Santos
Isatphone66	Isatphone Pro 1	ISP49	+870776380957	HCO Tanna
Isatphone67	Isatphone Pro 1	ISP50	+870776380958	Epi
Isatphone68	Isatphone Pro 1	ISP51	+870776380982	Prime Minister's Office
Isatphone70	Isatphone Pro 1	ISP53	+870776380984	Assessment Teams
Isatphone71	Isatphone Pro 1	ISP54	+870776382989	HCO Tanna
Isatphone69	Isatphone Pro 1	ISP52	+870776380983	Tanna – Hospital
Isatphone63	Isatphone Pro 2	ISP63	+870776382891	HCO Santos
No ref	Isatphone Pro 2	ISP66	870776320591	HCO Erromango
No ref	Isatphone Pro 2	ISP67	870776320590	HCO Erromango
No ref	Isatphone Pro 2	ISP68	870776320588	HCO Erromango
No ref	Isatphone Pro 2	ISP69	870776320589	HCO Erromango

BGAN	Model	SIM	Phone number	Attribution
BGAN39	Explorer 500	BVI60	TBC	Tanna – Isangel
BGAN45	Explorer 710	BVI31	+870772391931	Santo - Luganville
BGAN33	Explorer 700	BVI46	+870772546937	Tanna – ETC
No ref	Explorer 700	BVI32	+870772391932	Port Vila airport
BGAN42	Explorer 700	BVI47	+870772546938	In progress - Erromango
BGAN07	Explorer 500	BVI33	+870772391933	In progress - Erromango

## Forecasted operations

### 24/03/2015 - ERROMANGO – Port Narvine

With the GSM network still out-of-service on Erromango, one team has been sent to the island on a flight chartered by CARE International to offer free telephone calls via IsatPhone to the affected populations. 4 IsatPhones are currently deployed for this purpose in Erromango and operations should get underway on 24/03/15.